

***ASTE*EC** T560

Hydrostatic Drive
Chain Trencher



- **185 hp (138 kW) powertrain**
- **Compact size**
- **Rugged construction**
- **Optional Rock Saw available!**

• **Field-Proven Hydrostatic Trencher Drive**

- **Easy-to-use, Operator-friendly controls**
- **Variable-speed digging chain drive for changing ground conditions**
- **Forged Tailwheel provides smooth chain operation**
- **Machine leveling capability for trenching on sloped surfaces ($\pm 10^\circ$)**
- **Easy, ground-level access to routine service points**
- **Two-speed track drive motors**
- **Low profile digging chains for optimum tooth penetration**
- **Reversible conveyor for precise spoil placement**

Astec T560 Specifications

Weights & Dimensions

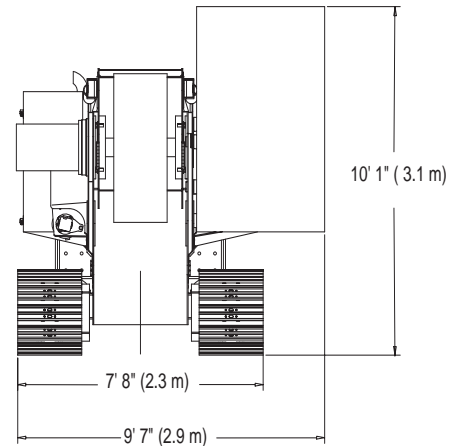
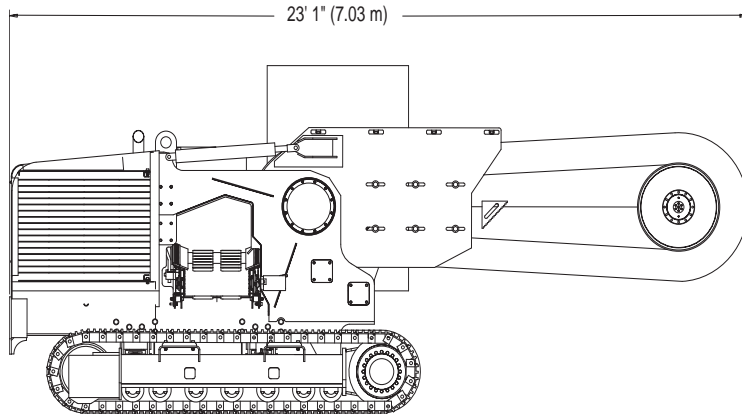

Transport Mode:

- Transport Height: 120" (3.05 m)
- Transport Width: 100" (2.54 m)
- Ground Clearance: 12" (305 mm)
- Approximate Shipping Weight: 26,000 - 34,000 lbs (11,793 - 15,422 kg)

Engine

- Type: Cummins C8.3 Turbocharged, after-cooled diesel
- Horsepower: 185hp (138 kW) @ 2200 RPM
- Torque: 631 ft-lbs (836 N*m) @ 1500 RPM
- Cooling System: Cooling Package rated for continuous operation @ 120° F (49° C)

Fuel Capacity

- 100 Gallon (378 L)
- 10 hrs capacity
- Single filter w/ water separation
- Cab mounted fuel gauge
- Approximately 9.5 gallon (36 L) per hour consumption

Hydraulic System

- Durst Pump drive
 - Dual Hydrostatic Track pumps
 - Rated @ 5000 psi (34474 kPa)
 - 33 gpm (125 l/min) max flow
- Auxiliary Pump rated at 3000 psi (20684 kPa)
 - Pressure and flow compensating
 - 27 gpm (102 l/min) max flow
- Variable displacement Trencher drive pump
 - 79 gpm (299 l/min) max flow
- 57 Gallon (215L) Hydraulic Reservoir capacity

Track Drive

- Berco (FL6) tracks, rollers and tensioner
- Closed loop Hydraulic drive motor w/ planetary final drive gearboxes
- Variable displacement pumps
- 2 speed track drive motors
- Length: 111" (2.8 m) Centerline to Centerline
- 20" or 24" (508 or 610 mm) wide steel track pads available (Single or triple grousers) with tilt frame
- 16" (406 mm) wide poly track pads available
- Spring applied, hydraulic release parking brakes
- Low Ground Pressure--5.3 psi (36.5 kPa) [w/ 6 ft. (1.8 m) boom, Enclosed Cab, 24" (610 mm) Track Pads]

Speed / Gradeability

- Transport: Infinitely variable from 0 - 1.9 mph (3.2 kph)
- Work: Infinitely variable from 0 - .8mph (1.3 kph)
- Gradeability: 50%
- Maximum Cross Slope 18%

Trencher

- Hydrostatic drive thru planetary gearbox
- Boom Travel
 - Up 0°
 - Down 58°
- End Idler 30" (762 mm) diameter single tailwheel w/ forged O.D. to limit wear. Optional 36" (914 mm) diameter double tailwheel available.
- Chain Speed
 - Dirt/soft rock: 0 - 740 fpm (226 m/s)
 - Hard rock: 0 - 420 fpm (128 m/s)

- Trench Depth: 4' - 8' (1.2 - 2.4 M)
- Trench Width: 10" - 24" (25 - 610 mm)
- Single or dual drive sprockets (Bolt-on, split sprockets for serviceability)

Spoil Conveyor

- Belt Speed: 0 - 1000 fpm (305 m/s) - left or right
- Belt Width: 24" (610 mm)
- Discharge Height: 51" - 55" (1295 - 1397 mm)
- Shift Travel: 31.5" (800 mm)

Rockwheel Attachments

- Quarry Saw
 - Trench Depth: 40" (1016 mm)
 - Trench Width: 2-3/4" (70 mm)
- Segmented Saw
 - Trench Depth: 40" (1016 mm)
 - Trench Width: 6", 8" or 10" (152, 203 or 254 mm)

Options

- Truck Loading Conveyor
- Automatic depth control via laser interface
- Rigid Tracks
- Enclosed operators station - Pressurized, A/C and heat (factory- or field installed)
- Automatic leveling capability for tilt frame

ASTEC

Due to our continuing product improvement, specifications are subject to change without notice.
 Headquarters: Astec Underground • 9600 Corporate Park Drive • Loudon, Tennessee 37774 USA
 USA Toll Free: 800-527-6020 • Tel: 865-408-2100 • Fax: 865-458-8575
www.astecunderground.com

