

MAXI-SNEAKER

SERIES D

ASTEC



BREAKTHROUGH SOLUTIONS



MAXI-SNEAKER SERIES D

The Astec line of walk-behind and ride-on utility trenchers, vibratory plows and horizontal directional drills along with related parts and accessories offers users a broad choice of underground construction solutions.

The forerunners of the Astec machines were developed by Charles Davis in 1959. Recognized as an industry leader, Davis trenchers were renowned for their innovative designs and rugged reliability. The line was purchased by Case in 1969, and the machines carried the Case-Davis label until the mid 1970s when the Davis name was dropped. Case nurtured the line until 2002 when it was sold to Astec Underground and the machines received the Astec brand.

Astec Underground continues to enhance the line's reputation for durability. Mainstay models like the Maxi-Sneaker and TF300B still have a respected place in the Astec lineup. Innovative walk-behind trenchers like the RT130 and RT160 are quickly joining them. These newly engineered units pay homage to the Astec heritage while confidently demonstrating the company's vision for the future.

Astec products are manufactured at the company's 360,000 square-foot facility in Loudon, Tenn., alongside the company's Trenchor line of rock trenchers, surface miners, road miners, and related equipment. Astec has owned the Trenchor brand since 1988. The combination of these respected names provides customers with unsurpassed choices to meet their trenching needs.

Astec products are sold and supported through a worldwide network of 47 dealers that operate more than 94 locations. These dealers sell new and used Astec machines, and provide the parts and service to help customers minimize downtime and get needed repair parts.

Visit www.astecunderground.com to learn about the full line of Astec Underground products or to contact the company for more information.

MORE MANEUVERABILITY

HYDRAULIC POWER STEERING ALLOWS UNIT TO ARTICULATE A FULL 28-DEGREES TO THE LEFT OR RIGHT OF CENTER FOR MINIMUM INSIDE TURNING RADIUS OF 72 INCHES (1,829 MM). A 10-DEGREE FRAME OSCILLATION PROVIDES WHEEL-TO-GROUND CONTACT WHEN PLOWING OVER ROUGH TERRAIN OR WHEN CROSSING OPEN TRENCH LINES.

CONTROL AT YOUR FINGERTIPS

SYSTEM GAUGES AND INDICATOR LIGHTS ARE GROUPED FOR HIGH VISIBILITY. LOW-EFFORT, DUAL-LEVER GROUND DRIVE CONTROLS FOR CREEP AND TRANSPORT OFFER PRECISION CONTROL WHEN WORKING, AND TOP-END TRAVEL SPEEDS WHEN TRANSPORTING.



OPTIONAL: TRENCHER

FRONT-MOUNTED TRENCHER WITH DIG DEPTH OF 24 OR 36 INCHES (610 OR 914 MM) IS DRIVEN BY HYDRAULICS WITH A RELIEF VALVE TO PROTECT COMPONENTS FROM SHOCK LOAD.

OPTIONAL: PLOW

P-40 AND P-75 VIBRATORY CABLE PLOWS ARE CAPABLE OF INSTALLATIONS UP TO 24 INCHES (610 MM) DEEP. BURIAL DEPTH IS MAINTAINED WITH POSITIVE HYDRAULIC DOWN PRESSURE.



OPTIONAL: ROCKWHEEL

QUICKLY CUT THROUGH CONCRETE, ASPHALT, OR ANY TOUGH MATERIAL WITH THE OPTIONAL ROCKWHEEL. CUTTING DEPTH IS UP TO 18 INCHES (610MM) WITH WIDTHS OF 3, 4 OR 5 INCHES (76, 102, OR 127 MM).



OPTIONAL: DUAL WHEELS

EASY-ON, EASY-OFF DUAL WHEELS MINIMIZE IMPACT ON SOFT TERRAIN AND INCREASE TRACTION. SINGLE WHEEL HUBS CAN BE MOUNTED INWARD OR OUTWARD FOR NARROW WIDTH OR ADDED STABILITY WHILE OPERATING ON SLOPES.



DEUTZ POWER

DEUTZ D2009L3, 3-CYLINDER, 4-STROKE, LIQUID COOLED ENGINE PROVIDES 37 HP (27 kW) @ 3,000 RPM. THIS POWERPLANT IS 300 POUNDS HEAVIER THAN THE SERIES C ENGINE, WHICH MEANS ADDITIONAL TRACTION WHILE TRENCHING AND PLOWING.

OPTIONAL: HYDRA-BORER SYSTEM

HYDRA-BORER SYSTEM IS USEFUL FOR BORING BENEATH DRIVEWAYS AND SIDEWALKS. ITS HIGH ROTATIONAL TORQUE CAN BORE THROUGH DIFFICULT SOIL CONDITIONS, EVEN WHEN BACKREAMING.



BREAKTHROUGH SOLUTIONS

MAXI-SNEAKER SERIES D

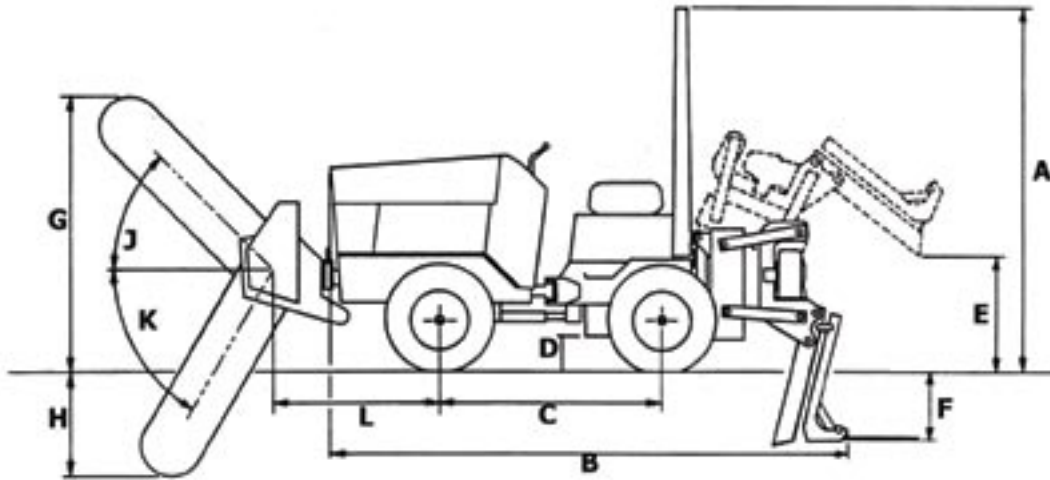

BASIC SPECS

- Deutz D2009L3, 3-cylinder, 4-stroke, liquid-cooled, naturally aspirated, diesel engine
- Gross horsepower: 37 hp (27.6 Kw) @ 3,000 RPM
- Net SAE horsepower: 35 hp (26.1 Kw) @ 3,000 RPM
- Torque: 76 ft-lbs (103 Nm) @ 1,800 RPM
- Bore/stroke: 3.54 x 3.54 inches (90 x 90 mm)
- Displacement: 105 in³ (1.72 L)
- Ground drive Hydrostatic pump & motor
- Axles Limited slip
- Steering Articulated
- Plow Drive Hydraulic gear pump to gear motor
- 16.4 GPM (62.1 L/min)
- Plow options
- P-40 — 2,381 vpm; max. depth: 24 in (610 mm)
- P-75 — 2,000 vpm; max. depth: 30 in (762 mm)
- Tires 23 x10.5x12 or 26x12x12
- Operating weight w/ 26x12x12 tires
- P-40 — 2,657 lbs (1,205 kg)
- P-75 — 2,963 lbs (1,344 kg)

ENGINE SPEEDS

Full throttle, no load 3,300 RPM
 Idle 900 RPM

ELECTRICAL SYSTEM

Battery 12 volt, 685 cold cranking amps
 Alternator 50 amp
 Starter 12 volt, 1.87 hp (1.4 kW)

TRAVEL SPEEDS

23x10.5x12 Tires

Transport — forward and reverse 0 to 3.5 mph (0 to 5.6 km/h)
 Working — forward and reverse 0 to 2.2 mph (0 to 3.6 km/h)

26x12x12 Tires

Transport — forward and reverse 0 to 3.9 mph (0 to 6.3 km/h)

Working — forward and reverse 0 to 2.5 mph (0 to 4.0 km/h)

BASIC MACHINE DIMENSIONS

- A. Height to top of ROPS: 26x12x12 tires 81.9 in (2,080 mm)
 23x10.5x12 80.4 in (2,042mm)
- B. Length with plow: Type P-40 118.0 in (2,997 mm)
 Type P-75 130.0 in (3,302 mm)
- C. Wheelbase 48.0 in (1,219 mm)
- D. Ground clearance: 26x12x12 tires 7.9 in (201 mm)
 23x10.5x12 tires 6.4 in (163 mm)
- E. Plow blade clearance with 26x12x12 tires:
 Type P-40 — 18 in (457mm) blade 24.0 in (610 mm)
 Type P-75 — 18 in (457mm) blade 16.9 in (430 mm)
- F. Depth of soil cover:
 Type P-40 & P-75 — 18 in (457mm) blade 18 in (457 mm)
- G. Boom height with 48-in boom 72.0 in (1,829 mm)
- H. Trench depth, maximum with 48-in boom 36 in (914 mm)
- J. Boom travel, up 45 degrees
- K. Boom travel, down 60 degrees
- L. Trencher headshaft to wheelbase 38.5 in (978 mm)

APPROXIMATE WEIGHT

Total (with P-40 Plow) 2,601 lbs (1,180 kg)
 Weight includes 23x10.5x12 tires, plow, and ROPS

OPTIONAL EQUIPMENT

- Hydra-Borer System
- P-40 & P-75 Plows
- Reel Carrier
- Trencher
- EarthPro Ground Engaging Systems Digging Chain
- Dual Wheels
- Wheel Weights
- Rockwheel

IMPORTANT: Astec Underground reserves the right to change these specifications without notice and without incurring any obligation relating to such change. This literature has been published for world-wide circulation. Availability of some models and equipment builds vary according to the country in which the equipment is used. The illustrations and text may include optional equipment and accessories and may not include all standard equipment. Your Astec dealer/distributor will be able to give you details of the products and their specifications available in your area.

NOTE: All specifications are stated in accordance with SAE Standards or Recommended Practices, where applicable.

© 2006 ASTEC UNDERGROUND. All Rights Reserved. ASTEC_MAXI-D_12_06

ASTEC UNDERGROUND an Astec Industries Company

9600 CORPORATE PARK DR • LOUDON, TN 37774 USA • 800.527.6020 FAX 865.458.8575 • astecunderground.com

